



Syntron CheckMate® Paper Jogger

For all your Check 21 Act processing needs

Syntron Strategic Solutions to Enhance Your Work Flow

Could your strategic work flow benefit from a little streamlining? The **Syntron**® CheckMate® Jogger from **FMC** Technologies fits the bill.

- **Compact size**
 - Strategic placement close at hand
 - Weighs less than 10 pounds
 - Ideal for jogging small quantities of checks and envelopes
- **Simple operation**
 - Convenient stop/start bar
- **Advanced design**
 - Electromagnetic design allows continuous operation and eliminates overheating unlike motor-driven units
- **Proven Reliability**
 - Enjoy many years of reliable, maintenance-free service
- **Quality**
 - Units warranted to be free of defects in material and workmanship for one year from date of shipment
- **Safety**
 - Self-enclosed units, no exposed drive parts
 - Electromagnetic design eliminates sparking or burn-up associated with overheating
 - 115V / 60 Hz units are UL/CUL approved

Syntron® CheckMate® Paper Jogger

Technical Data

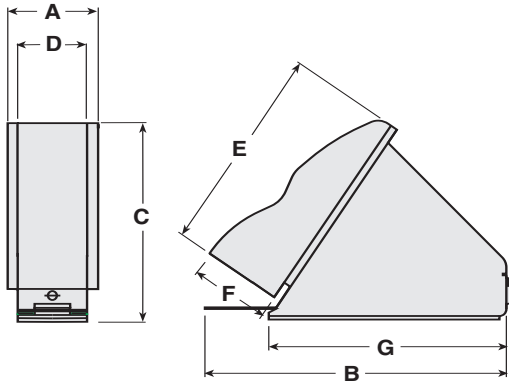

<i>Dimensions</i>							
	A	B	C	D	E	F	G
Inches	3 ³ / ₁₆	10 ⁵ / ₈	7	2 ¹ / ₂	7 ⁵ / ₁₆	2 ³ / ₄	8 ³ / ₈
mm	81	270	178	64	186	70	213

Input Amps,	115 V, 60 Hz	4.0
Net Weight	10 lbs	4.5 kg
Shipping Weight	12 lbs	5.4 kg

For more than 60 years, FMC Technologies has manufactured Syntron® Electromagnetic Vibrating Paper Joggers to meet the varied needs of business and industry.

As the world's largest manufacturer of paper joggers, our commitment to our customers is unparalleled in the industry with the reliability and high-performance of our products.



FMC Technologies

**ISO 9001
CERTIFIED**